

# TABLE OF CONTENTS

	Page
<b>For Future Reference</b> .....	
<b>Consumer Publications</b> .....	
<b>Important Safety Instructions</b> .....	2-
<b>Electronic Clock and Oven Control</b> .....	5-
• Explanation of Function Pads .....	
• Setting the Clock and Timer .....	
<b>Using Your Oven</b> .....	7-1
• Oven Characteristics .....	
• Pilotless Ignition .....	
• Oven Vent .....	
• Oven Light .....	
• Fan .....	
• Setting the Oven Controls .....	
• Preheating .....	
• Oven Racks .....	
• Rack Positions .....	
• General Baking Tips .....	
• Baking Chart .....	
• Common Baking Problems and Why They Happen .....	
• Roasting .....	
• Broiling .....	
• Programmed Oven Operations .....	14-
<b>Maintenance</b> .....	16-
• Oven or Broiler Door .....	
• Oven Bottom .....	
• Broiler Bottom .....	
• Oven Light .....	
• Electrical Connection .....	
• How to Remove Wall Oven for Servicing or Cleaning .....	
<b>Care and Cleaning</b> .....	18-
• Cleaning Chart .....	
• Continuous Cleaning Oven .....	
<b>Service Information</b> .....	20-
• Adjusting the Oven Thermostat .....	
• Fault Codes .....	
• Before You Call For Service .....	
<b>Wall Oven Warranty</b> .....	Back P

## FOR FUTURE REFERENCE

Congratulations on your choice of a Maytag oven! As you use your new oven we know you will appreciate the many features that provide excellent performance, ease of cleaning, convenience and dependability.

New features have dramatically changed today's cooking appliances and the way we cook. It is therefore very important to understand how your new oven operates before you use it. On the following pages you will find a wealth of information regarding all aspects of your oven. By following the instructions carefully, you will be able to fully enjoy and properly maintain your Maytag oven and achieve excellent results with the food you prepare.

Should you have any questions about using your Maytag oven, call or write us. Be sure to provide the model and serial numbers of your oven.

MAYTAG CONSUMER EDUCATION  
 ONE DEPENDABILITY SQUARE  
 NEWTON, IOWA 50208  
 (515) 791-8911  
 (Mon.-Fri., 8 am-5 pm CST)

For future reference we suggest you retain this manual after recording the model number and serial number of this wall oven in the spaces provided. This information can be found on the data plate located under the broiler oven bottom. See page 16 for instructions on removing the broiler bottom.

Model Number

Serial Number

**IMPORTANT:** Retain the proof of purchase documents for warranty service.

**NOTE:** In our continuing effort to improve the quality of our products, it may be necessary to make changes to the appliance without revising this book. As an example, the knob on your appliance may not look like an illustration in this book.

**Be sure you read the IMPORTANT SAFETY INSTRUCTIONS on pages 2-4 before you start to use this wall oven.**

## CONSUMER PUBLICATIONS

For more information, order the following booklets from Maytag at the prices indicated. Send your name, address, booklet title, form number and payment to: Maytag Consumer Education, One Dependability Square, Newton, IA 50208. Allow 4-6 weeks for delivery.

- Cooking Made Simple - 272YG ..... 50 cents
- Cooktop Choices - 298YG ..... 50 cents
- Appliance Buying Guides ..... 50 cents EACH
  
- Washer ..... 211YG
- Dryer ..... 212YG
- Dishwasher ..... 213YG
- Electric Range ..... 214YG
- Gas Range ..... 215YG
- Refrigerators ..... 276YG

# IMPORTANT SAFETY INSTRUCTIONS

Read all instructions before using this appliance. The following instructions are based on safety considerations and must be strictly followed to eliminate the potential risks of fire, electric shock or personal injury.

**WARNING: If the information in this manual is not followed exactly, a fire or explosion may result causing property damage, personal injury or death.**

- Do not store or use gasoline or other flammable vapors and liquids in the vicinity of this or any other appliance.
- **WHAT TO DO IF YOU SMELL GAS**
  - Do not try to light any appliance
  - Do not touch any electrical switch; do not use any phone in your building.
  - Immediately call your gas supplier from a neighbor's phone. Follow the gas supplier's instructions.
  - If you cannot reach your gas supplier, call the fire department.
- Installation and service must be performed by a qualified installer, service agency or the gas supplier.

## Installation

Installation of the appliance must conform with local codes or, if no codes exist, with the current National Fuel Gas Code. Installation and adjustment of the appliance must be performed **ONLY** by a qualified installer or service technician in accordance with the Installation Instructions. See accompanying Installation Instructions.

Have the installer show you the location of the gas shut off valve and how to shut it off in an emergency.

Be certain all packing materials are removed from the oven before operating, to prevent fire or smoke damage should the packing material ignite.

Observe all instructions for minimum clearances to any combustible surfaces. These should be in accordance with information on the rating plate and with national fire laws.

If the appliance is installed near a window, proper precautions should be taken to prevent the curtains from blowing over the burners creating a **FIRE HAZARD**.

## Gas Type

All models are adjustable for use with **NATURAL** or **LP** (bottled) gas. An appliance adjusted for one type of gas **cannot** be used

with the other type until adjustments are made by a qualified service technician.

## Gas Odor

If gas odor is detected, cut off the gas supply to the appliance. Then, call your installer or local gas company to have the leak checked. **Never use a match or other flame to locate a gas leak.**

## Servicing

Electrical supply must be disconnected before servicing appliance.

Do not repair or replace any part of your appliance unless specifically recommended in this manual. All other servicing should be referred to a qualified technician.

## IN CASE OF FIRE:

1. Turn oven controls off immediately.
2. Smother fire or flame with a dry chemical or foam-type extinguisher, or baking soda. Do not use water on a grease fire.
3. If the fire is in the oven, smother it by closing the oven door.

## General

Misuse of appliance doors, such as stepping on or leaning or sitting on the door, may result in possible tipping of the appliance, breakage of door and serious injuries.

**CAUTION:** Do not use an appliance as a stool to cabinets above.

Keep area around appliance clear and free from combustible materials, gasoline, and other flammable vapors and materials.

In the event of a prolonged power failure, oven **CANNOT** be operated during a power failure.

Never use your oven to warm or heat the room. No cooking appliance should ever be used as a space heater. This instruction is based on safety considerations to prevent potential hazard to the consumer as well as damage to the appliance.

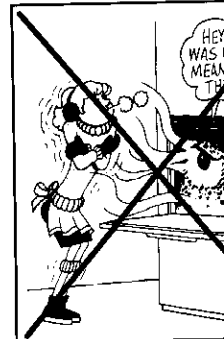

## Cooking Safety

If flame should go out during cooking, turn burner off. **If gas has collected and a strong gas odor is detected, wait 5 minutes for gas odor to disappear before relighting burner.**

Slide oven rack out to add or remove food, using dry, sturdy pot holders. Always avoid reaching into oven to place or remove food.

Do not use oven as a storage area for food or cooking utensils. This instruction is based on safety considerations to prevent potential hazard to user and to the appliance.

Use caution when wearing garments made of flammable material to avoid clothing fires. Loose fitting or long-hanging-sleeved apparel should not be worn while cooking. Clothing may ignite or catch utensil handles.

Use dry, sturdy pot holders. Damp pot holders may cause burns from steam. Dish towels or other substitutes should never be used as pot holders because they can trail across hot burners and ignite or get caught on appliance parts.

Never heat an unopened container in the oven. Pressure build-up may cause container to burst resulting in serious personal injury or damage to the oven.

Use care when opening oven door. Let hot air or steam escape before removing or replacing food.

Always place oven racks in the desired positions while oven is cool. If a rack must be moved while hot, be careful to avoid contact of pot holders with oven burner flame.

Use aluminum foil **only** as instructed. Improper use of aluminum foil may cause damage to the appliance, affect cooking results adversely and can also result in shock and/or fire hazards.

Do not cover broiler inset with foil. Use a broiler pan that allows grease to drip below the insert, away from the broiler flame to minimize chance of grease fires.

## Prepared Food Warning

Follow the food manufacturer's instructions. If a plastic frozen food container and/or its film cover distorts, warps or is otherwise damaged during cooking, immediately discard the food and its container. The food could be contaminated.

## Child Safety

Do not leave children alone or unsupervised near the appliance when it is in use or is still hot.

Children should never be allowed to sit or stand on any part of the appliance.

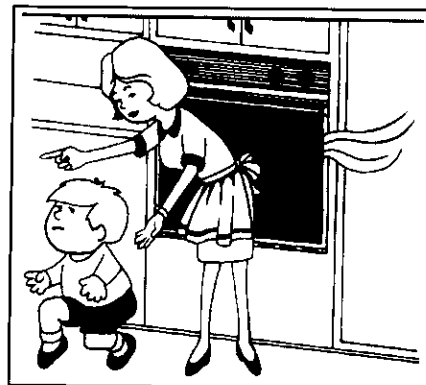

Children **MUST** be taught that the appliance and utensils in or on it can be hot.

Children should be taught that an appliance is not a toy. They should not be allowed to play with controls or other parts of the unit.

Let hot utensils cool in a safe place, out of reach of small children.



**Caution:** Do not store items of interest to children in cabinets above an appliance. Children climbing on the appliance to reach items could be seriously injured. An appliance should not be used as a step stool to cabinets above.

## Utensil Safety

Use only pans with handles that are easily grasped and stay cool. Avoid using unstable, warped, easily tipped or loose handled pans. Do not use pans if their handles twist and cannot be tightened. Pans that are too heavy to move when filled with food may also be hazardous. Use only glass cookware that is recommended for use in the oven.

Be sure utensil is large enough to properly contain food and avoid boilovers.

## Grease

Use extreme caution when moving the grease kettle or disposing of hot grease. Hot grease is flammable. Avoid letting grease deposits collect around appliance, range hood, or vent fan. Do not leave container of grease around a cooking appliance. Always let quantities of hot fat used for deep fat frying cool before attempting to move or handle. In the event of a grease fire, **do not** attempt to move pan. Cover pan with a lid to extinguish flame and turn burner off. Do not douse flame with water. Use a dry chemical or foam-type extinguisher, if available, or sprinkle heavily with baking soda.

Spills or boilovers which contain grease should be cleaned up as soon as possible. If they are allowed to accumulate, they could create a **fire hazard**.

## Venting

Never block oven vent or air intakes. Do not obstruct the flow of combustion and ventilation air. Restriction of air flow to the burner prevents proper performance.

Avoid touching oven vent area while oven is on and for several minutes after oven is turned off. Some parts of the vent and surrounding area become hot enough to cause burns.

## Cleaning

Turn off all controls and wait for appliance parts to cool before touching or cleaning them.

Touching a hot oven light bulb with a damp cloth could cause the bulb to break. Should the bulb break, disconnect power to the oven before trying to remove the bulb to avoid electrical shock.

Clean oven with caution. If a wet sponge or cloth is used to wipe spills on a hot cooking area, be careful to avoid steam burns. Some cleaners can produce noxious fumes if applied to a hot surface.

## Storage Above Oven

To eliminate the hazard of reaching over hot surfaces, cabinet storage should not be provided directly above a unit. If such storage

is provided, it should be limited to items which are used infrequently and which are safely stored in an area subjected to heat from an appliance. Temperatures in storage area above the unit may be unsafe for some items such as volatile liquids, cleaners or aerosol sprays.

## Plastics

Many plastics are vulnerable to heat. Keep plastics away from parts of the appliance which may become warm or hot.

## Aerosol Sprays

Many aerosol-type spray cans are **EXPLOSIVE** when exposed to heat and may be highly flammable. Avoid their use or storage near a hot appliance.

## Important Safety Notice and Warning

The California Safe Drinking Water and Enforcement Act of 1986 (Proposition 65) requires the Governor of California to publish a list of substances known to the State of California to cause cancer or reproductive harm, and requires businesses to warn customers of the potential exposures to these substances.

Users of this appliance are hereby warned that the burning of gas can result in low-level exposure to some of the listed substances including benzene, formaldehyde and soot due primarily to the incomplete combustion of natural gas or liquid petroleum (LP) fuels. Properly adjusted burners will minimize incomplete combustion. Exposure to these substances can also be minimized by properly venting the burners to the outdoors.

## Baking Accessories

This appliance has been tested for safe performance using conventional cookware. Do not use any devices or accessories that are not specifically recommended in this manual. Do not use add-on oven convection systems. The use of devices or accessories that are not expressly recommended in this manual could create serious safety hazards, result in performance problems, and reduce the life of the components of the appliance.

**SAVE THESE INSTRUCTIONS**

## ELECTRONIC CLOCK AND OVEN CONTROL

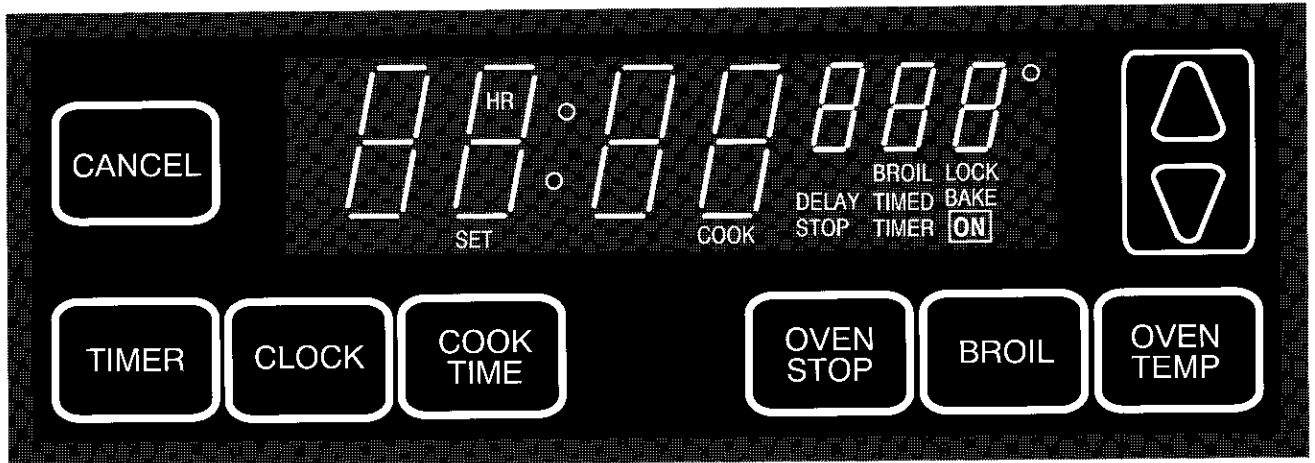

The electronic clock and oven control on your Maytag wall oven is used for the time-of-day clock, timer, bake, broil, and programmed operation functions. A beep will sound each time a function pad is pressed.

The display on the control will flash when power is first supplied to the wall oven or if there is a power failure. Once the time-of-day clock has been set (see *Setting the Clock*, page 6), the display will stop flashing.

**The oven will automatically turn off if it is left on for 12 hours.**

**NOTE:** The electronic control is equipped with a self-diagnostic feature for service use ONLY. If a fault code (F plus a number, ex. F1) appears in the display along with a continuous beeping sound, press the CANCEL pad. See page 20 if the fault code reappears in the display.

### Explanation of Function Pads

The following pads are found on your Maytag electronic clock and oven control:

#### Cancel Pad

Press this pad to cancel all operations except the time-of-day clock and timer. If you are ever unsure if you've programmed the control correctly, press the CANCEL pad and start over.

#### ▲ and ▼ Pads

Press or press and hold these pads to enter the time or temperature desired. These pads are also used to select Hi or Lo broil.

#### Timer Pad

The timer can be set from 1 minute to 9 hours, 50 minutes. It will count down by seconds (when set for 1 minute) or minutes (when set for 2 minutes or more time). See page 6 for instructions on setting the timer.

#### Clock Pad

Use this pad to set the time-of-day clock. For instructions, see page 6.

You may also press this pad to recall the current time of day. For example, if the timer is counting down in the display, press the CLOCK pad to return the current time to the display. The timer will continue to count down and a signal will sound when the time expires.

#### Cook Time / Oven Stop Pads

These pads are used to program the oven to start and stop automatically, either immediately or at a later time. For detailed information on using Programmed Oven Operations, see pages 14 to 15.

#### Broil Pad

Use this pad to select broil. Two heat selections are available for broiling - Hi and Lo. See page 13 for more broiling information.

#### Oven Temp Pad

This pad is used to select the oven temperature. The oven temperature is set by pressing this pad and the ▲ or ▼ pad. Additional baking and roasting information can be found on pages 7 to 12.

## SETTING THE CLOCK AND TIMER

### Clock

#### To set the time-of-day clock:

1. Press the CLOCK pad once. The words "Set Time" will flash in the display.
2. Set the correct time of day using the ▲ and ▼ pads.
  - To change the time by one minute, press either pad **once**.
  - To change the time in increments of 10 minutes, **press and hold** either pad.

When the power is first supplied to the oven or if there has been a power failure, the display will flash. Follow above instructions to set the clock. The clock time cannot be changed when the oven is set for a cook or timing operation. Cancel the operation to set the clock.

Press the CLOCK pad to recall the time of day when another function is displayed.

### Timer

#### To set the timer:

1. Press the TIMER pad once. The words "Timer" will flash in the display.
2. Set the desired time using the ▲ and ▼ pads.
  - Press either pad **once** to change the time by 1 minute (if the Timer is set up to 1 hour), 5 minutes (if the Timer is set for over 1 hour), or 10 minutes (if the Timer is set for over 2 hours).
  - **Press and hold** either pad to change the time in 5 minute or 10 minute increments, depending upon the time set in the display.

The TIMER can be set from 1 minute (0H:01) up to 9 hours and 50 minutes (9 HR:50).

The timing operation will start automatically. Colons will flash in the display to indicate timing operation. One long continuous beep will signal the end of the timing operation. "End" will briefly appear in the display. The time of day will automatically reappear in the display. The TIMER pad does not control the oven.

**To cancel:** Press and hold the TIMER pad for 3 seconds. The time of day will reappear after a slight delay.

---

## USING YOUR OVEN

### Oven Characteristics

Every oven has its own characteristics. You may find that the cooking times and temperatures you were accustomed to with your previous oven may need to be altered slightly with the new oven. Please expect some differences with the new appliance. Compare your recipes with the baking chart on page 10 or refer to a reliable cookbook for proper recommendations. It is normal to notice some differences between this appliance and your old one.

### Pilotless Ignition

Your Maytag wall oven is equipped with pilotless ignition. Heat from the Glow Bar ignitor lights the oven burner. With this type of ignition system, **the oven will not operate during a power failure or if the wall oven is disconnected from the wall outlet.** No attempt should be made to operate the oven during a power failure.

### Oven Vent

The oven vent is located between the control panel and oven door. Do not block this opening. It is important that the flow of hot air from the oven and fresh air to the burner be unrestricted. Do not touch the vent opening or nearby surfaces during oven operation as they may become hot.

### Oven Light

The oven light is turned on by pushing the rocker switch marked OVEN LIGHT on the control panel.

### Fan

A fan automatically turns on whenever the oven is set for a cooking operation to ensure long-life of the clock and oven controls. The fan will automatically turn off when the oven has cooled.

## Setting The Oven Controls

### To set your oven for baking or roasting:

1. When cool, position the racks in the oven according to what you are baking.
2. Press the OVEN TEMP pad. "Bake" and 000° will appear in the display.
3. Press either the ▲ or ▼ pad once and 350° will appear in the display. Press the ▲ or ▼ pad until the desired oven temperature is displayed.

The word ON will light in the display, the oven and cooling fan will turn on. The temperature display will rise in 5° increments while the oven is preheating. A beep will sound to indicate that the oven has preheated. Allow 10 to 15 minutes for preheating.

4. Place the food in the center of the oven, allowing a minimum of one to two inches between the utensil(s) and the oven walls.
5. Check the food for doneness at the minimum time given in the recipe. Cook longer if necessary. Turn the oven off by pressing the CANCEL pad. Remove the food from the oven.

## Preheating

Always preheat the oven if called for in the recipe or on the package directions. Preheating is necessary for proper baking results. It is not necessary to preheat for roasting.

Allow the oven to heat until the desired oven temperature is reached (approximately 10 to 15 minutes). A beep will sound when the oven is preheated.

Selecting a temperature higher than the desired temperature will **not** preheat the oven any faster. Preheating at a higher temperature, may have a negative effect on baking results.



## Oven Racks

The two oven racks are designed with a lock-stop position to keep the racks from accidentally coming completely out of the oven when there is food placed on them.

**To remove:** Be sure the rack is cool. Pull the rack straight out until it stops. Tilt the front end of the rack up and continue pulling the rack out of the oven.

**To replace:** Tilt the front end of the rack up and place the rack between the rack supports. Slide it back until it clears the lock-stop position. Lower the front and slide the rack straight in. Pull the rack out to the lock-stop position to be sure it is positioned correctly and then return it to its normal position.

**Do not cover the oven bottom or an entire oven rack with aluminum foil or place foil directly under a utensil.** To catch spillovers, cut a piece of foil a little larger than the pan and place it on the rack below the utensil.

## Rack Positions

It is important that air can circulate freely within the oven and around the food. To help ensure this, place food in the center of the oven rack. Allow one to two inches between the edge of the utensil(s) and the oven walls. If cooking on two racks, stagger the food to ensure proper airflow.

Do not attempt to change the rack positions when the oven is hot. Use the following guidelines when selecting the proper rack position.

**Never** place pans directly on the oven bottom.

<b>Rack 1:</b> (lowest position)	Used for roasting large cuts of meat and large poultry, frozen pies, souffles, angel food cake, or for some two-rack baking.
<b>Rack 2:</b>	Used for most one-rack baking and for roasting small cuts of meat, casseroles, baking loaves of bread, cakes (in either tube, bundt, or loaf pans) or for some two-rack baking.
<b>Rack 3:</b>	Used for some two-rack baking.
<b>Rack 4:</b> (highest position)	Used for some two-rack baking.

Place food in oven on center of rack. Allow one to two inches between edge of utensil and oven sides or adjacent utensils. If cooking on two racks, stagger foods on racks. Use rack positions 2 and 4 or 1 and 3 when cooking on two racks.

---

## General Baking Tips

- **Use a reliable recipe** and accurately measure ingredients. **Carefully follow directions** especially for oven temperature and cooking time.

- **Use the correct rack position.** Baking results may be affected if the wrong rack is used.

- \* Top browning may be darker if food is located toward the top of the oven.
- \* Bottom browning may be darker if food is located toward the bottom of the oven.
- \* When using two racks for baking, allow enough space between the racks for proper air circulation. Browning and cooking results will be affected if air flow is blocked.

- **Utensil material and size** play an important part in baking results, especially the amount of browning. Always use the type and size of utensil called for in the recipe. Many pans have the measurements marked on them. If there are no measurements, measure the inside width and length of the pan. Cooking times or cooking results may be affected if the wrong size utensil is used.

- \* **Shiny metal pan** reflects heat away from the food, produces lighter browning and a softer crust. Use shiny pans for baking cakes or cookies.
- \* **Dark metal pan or a pan with an anodized (dull) bottom** absorbs heat, produces darker browning and a crisper crust. Use this type of pan for pies, pie crusts or bread.

- \* If using **oven-proof glassware**, or **dark pans such as Ekco's Baker's Secret** bakeware reduce the oven temperature by 25°F except when baking pies or bread in glassware. Use the same baking time as called for in the recipe. Use this type of pan for pies or breads.

- \* For optimum baking results, bake cookies and biscuits on a **flat** cookie sheet. If the pan has sides, such as a jelly roll pan, browning may not be even.

- **Allow hot air to flow freely through the oven** for optimum baking results. Improper placement of pans in the oven will block air flow and may result in uneven browning. For optimum browning and even cooking results:

- \* Do not crowd a rack with pans. Never place more than one cookie sheet, one 13x9x2-inch cake pan or two round cake pans on one rack.
- \* Stagger pans when baking on two racks so one pan is not directly over another pan.
- \* Allow one to two inches between the pan and the oven walls.

- **Check the cooking progress at the minimum time** recommended in the recipe. If necessary, continue checking at intervals until the food is done. If the oven door is opened too frequently, heat will escape the oven; this can affect baking results and wastes energy.

- **If you add additional ingredients** or alter the recipe, expect cooking times to increase or decrease slightly.

## Baking Chart

You may find these guidelines helpful when comparing the baking times, temperatures and oven positions of commonly baked foods.

Product & Type	Pan Size	Rack Position*	Temperature	Time (Minutes)
<b>Cake</b>				
Chocolate, two layers	9"	2 or 3	350°	30-35
Yellow, two layers	9"	2 or 3	350°	30-35
White, two layers	9"	2 or 3	350°	25-30
Bundt	tube	1 or 2	350°	35-45
Cupcakes		2 or 3	350°	15-20
Sheet Cake	15" x 10"	2 or 3	350°	20-25
Angel Food	tube	1	375°	30-40
Pound Cake	loaf	1 or 2	325°	40-50
Snacking Cake	8" x 8"	2 or 3	375°	30-35
<b>Pies</b>				
Two Crust				
Fruit, fresh	9"	1 or 2	400° - 425°	35-45
Fruit, frozen	9"	1	400° - 425°	45-55
One Crust				
Custard, fresh	9"	1 or 2	350°	35-45
Pie Shell	9"	1 or 2	400°	8-12
<b>Cookies</b>				
Chocolate Chip		2 or 3	350° - 375°	8-12
Peanut Butter		2 or 3	350° - 375°	8-12
Sugar		2 or 3	350° - 375°	8-12
Brownies	8" x 8"	2 or 3	350°	30-35
<b>Breads</b>				
Yeast				
Loaf	loaf	1 or 2	375°	30-40
Rolls		2 or 3	375° - 400°	15-20
Quick				
Loaf, nut or fruit	loaf	2 or 3	350°	45-55
Gingerbread	9" x 9"	2 or 3	350°	40-45
Cornbread	8" x 8"	2 or 3	400° - 450°	15-20
Cornbread Muffins		2 or 3	400°	10-15
Biscuits		2 or 3	400° - 425°	10-15
Muffins		2 or 3	400°	15-20

\* The bottom rack position is #1.

\*\* Times are only approximate and may vary depending on the recipe used.

# Common Baking Problems and Why They Happen

If you have carefully followed the basic instructions and still experience poor results, these suggestions may be helpful:

Problem	Cause	Problem	Cause
<b>Slow baking or roasting.</b>	Baking or roasting time too short. Temperature too low. Oven out of calibration. Old oven out of calibration. Incorrect use of aluminum foil. Oven not preheated. Oven door opened frequently. Too many pans on racks.	<b>Excessive shrinkage.</b>	Too little leavening. Overmixing. Pan too large. Oven temperature too high. Baking time too long. Pans too close to each other or oven wall.
<b>Cakes are uneven.</b>	Pans touching each other or oven walls. Batter uneven in pans. Oven temperature too low or baking time too short. Range not level. Undermixing. Too much liquid.	<b>Crumbly or dry texture.</b>	Improper measurement of sugar, baking powder, liquid or fat. Old baking powder. Oven temperature too high. Baking time too long.
<b>Cakes high in the middle.</b>	Temperature too high. Baking time too long. Overmixing. Too much flour. Pans touching each other or oven walls.	<b>Uneven texture.</b>	Too much liquid. Undermixing. Oven temperature too low. Baking time too short.
<b>Cakes fall.</b>	Too much shortening or sugar. Too much or too little liquid. Temperature too low. Old or too little baking powder. Pan too small. Oven door opened frequently.	<b>Cakes have tunnels.</b>	Not enough shortening. Too much baking powder. Overmixing. Oven temperature too high.
<b>Cakes don't brown on the bottom.</b>	Using shiny metal pans. Incorrect rack position.	<b>Cakes crack on the top.</b>	Batter overmixed. Oven temperature too high. Too much leavening.
<b>Cakes don't brown on the top.</b>	Oven temperature too low. Overmixing. Too much liquid. Incorrect pan size or too little batter in pan. Oven door opened too often.	<b>Cakes not done in the center.</b>	Temperature too high. Pan too small.
<b>Cakes, cookies, biscuits too brown on the bottom.</b>	Oven not preheated. Pans touching each other or oven walls. Using glass, darkened, warped or dull finish metal pans. Incorrect rack position. Incorrect use of aluminum foil.	<b>Pie crust edges too brown.</b>	Oven temperature too high. Pans touching each other or oven wall. Edges of crust too thin.
		<b>Pies don't brown on the bottom.</b>	Using shiny metal pans.
		<b>Pies have soaked crust.</b>	Temperature too low at start of baking. Filling too juicy. Using shiny metal pans.

## Temperature Conversions

°Fahrenheit	200	250	275	300	325	350	375	400	425
°Celsius	100	120	140	150	160	180	190	200	220

## Roasting

Roasting is the method for cooking large, tender cuts of meat uncovered, without adding moisture.

### General Tips

Most meats are roasted at 325°F. It is not necessary to preheat the oven. Place the roasting pan on a rack which has been placed in either of the two lowest rack positions.

Use tender cuts of meat weighing three pounds or more. Some good choices are: beef rib, rib eye, top round, high quality tip and rump roast, pork loin roast, veal and lamb leg, shoulder roast and cured or smoked hams.

Season meat, if desired, either before or after roasting. Rub into the surface of the roast if added before cooking.

Place the meat fat-side-up on a rack in a shallow roasting pan. Placing the meat on a rack holds it out of the drippings, thus allowing better heat circulation for even cooking. As the fat on top of the roast melts, the meat is basted naturally, eliminating the need for additional basting.

The cooking time is determined by the weight of the meat and the desired doneness. For more accurate results, use a meat thermometer. Insert it so the tip is in the center of the thickest part of the meat. It should not touch fat or bone.

Remove the roast from the oven when the thermometer registers approximately 5°F below the doneness wanted. As the meat stands, the temperature will rise.

**NOTE:** For more information on cooking meat and poultry, contact the USDA Meat and Poultry Hotline at 1-800-535-4555.

### Roasting Chart (Thawed Meats Only)

Cut of Meat	Approximate Weight (pounds)	Oven Temperature in °F (not preheated)	Internal Temperature	Approximate Roasting Time (min. per pound)
<b>Beef</b>				
Rib Roast (cut-side-down)	4 to 8	325°	140° (rare) 160° (medium)	25-30 30-35
Rib Eye Roast	4 to 6	325°	140° (rare) 160° (medium)	25-30 30-35
Loin Tenderloin Roast	2 to 3	400°	140° (rare)	20-25
Top Sirloin Roast	3 to 6	325°	140° (rare) 160° (medium)	25-30 30-35
<b>Pork</b>				
Shoulder Blade Roast, Boneless	4 to 6	325°	160°	35-45
Shoulder Blade Roast	4 to 6	325°	160°	30-40
Loin Blade or Sirloin Roast	3 to 4	325°	160°	35-45
Ham, Half (fully cooked)	5 to 7	325°	140°	25-35
Ham, Half (cook-before-eating)	5 to 7	275°	160°	35-45
<b>Lamb</b>				
Shoulder Roast, Boneless	3-1/2 to 5	325°	160° (medium) 170° (well)	35-40 40-45
Leg, Whole	5 to 7	325°	160° (medium) 170° (well)	30-35 35-40
<b>Poultry</b>				
Turkey, unstuffed**	12 to 16	325°	180° - 185°	18-20
	16 to 20	325°	180° - 185°	16-18
	20 to 24	325°	180° - 185°	14-16
Turkey, Breast	3 to 8	325°	180°	30-40
Chicken, Fryer	2-1/2 to 3-1/2	375°	185°	20-24
Chicken, Roaster	4 to 6	375°	185°	20-25

\* Cooking times are approximate and may vary depending on the shape of the roast.

\*\* Stuffed turkeys take longer to cook; refer to cookbooks for approximate time.

# Broiling

Broiling is a method of cooking used for tender steaks, chops, hamburgers, chicken, fish, and some fruits and vegetables. The food is placed directly under the burner. The degree of doneness is determined by the distance between the meat and the burner, and the length of broiling time.

## General Tips

Broiling requires the use of the broiler pan and insert supplied with your range. It is designed to drain excess liquid and fat away from the cooking surface to prevent splatters, smoke and fire.

For easier clean-up, line the broiler pan (bottom piece) with aluminum foil and spray the insert with a non-stick vegetable coating. Do not cover the broiler insert with aluminum foil as this prevents fat from draining into the pan below.

To prevent excessive splattering and smoking, trim excess fat from the meat. Increasing the distance between the meat and the oven burner will also help.

The rack position you select for broiling depends on the thickness of the meat and the desired doneness. Thin cuts (3/4 to 1 inch) should be placed 2-3 inches from the heat; thicker cuts should be placed 3-6 inches from the heat. Broil until the top of the meat is

browned. It should be approximately half cooked by the time the top is browned.

Generally for a brown exterior and rare interior, the meat should be close to the burner. Place the pan further down if you want the meat well done.

If you plan to season the meat, it is better to do so after the surface has browned. Salt tends to delay browning which can result in overcooking. Salting before cooking also draws the juices out of the meat, causing dryness.

Never leave a soiled broiler pan in the oven after broiling. Drippings might become hot enough to ignite if exposed directly to the oven burner.

## Setting the Controls

1. Press the BROIL pad and press the ▲ or ▼ pad to select either Hi or Lo temperature as indicated in the display. Hi is used for most broiling operations. Lo should be selected when broiling thicker meats to the well-done stage (to prevent excessive browning) and when cooking foods for very short periods of time. Broiling times may increase if Lo is selected.
2. Place the broiler pan on the recommended rack position shown in the broiling chart and follow the suggested times.
3. Check the doneness by cutting a slit in the meat near the center to check the color.
4. To cancel or end the broiling operation, press the CANCEL pad.

## BROILING CHART

Until you become more familiar with your new oven, use the following chart as a guide when broiling foods.

FOOD	DONENESS	6-INCH BROILER		12-INCH BROILER	
		BROIL POSITION	TOTAL BROIL TIME	BROIL POSITION	TOTAL BROIL TIME
BACON	Well Done	Middle	Lo Broil 6-9 minutes	Middle	Hi Broil 8 - 12 minutes
BEEF PATTIES, 3/4-inch thick	Well Done	Middle	Hi Broil 14-18 minutes	Upper	Hi Broil 15 - 18 minutes
STEAKS, 1-inch thick	Rare	Middle	Hi Broil 12-14 minutes	Upper	Hi Broil 10 - 12 minutes
	Medium	Middle	15-18 minutes	Upper	12 - 14 minutes
	Well Done	Middle	18-21 minutes	Upper	13 - 16 minutes
CHICKEN, Pieces	Well Done	Middle	Lo Broil 30-40 minutes	Middle	Hi Broil 30 - 35 minutes
FISH, Fillet, 1/2-inch thick Steak, 1-inch thick	Flaky	Middle	Lo Broil 8-12 minutes	Upper	Lo Broil 7 - 10 minutes
	Flaky	Middle	13-16 minutes	Upper	12 - 15 minutes
HAM SLICE, 1/2-inch thick (precooked)	Warm	Middle	Hi Broil 8-10 minutes	Upper	Hi Broil 9 - 12 minutes
PORK CHOPS, 1-inch thick	Well Done	Middle	Hi Broil 24-28 minutes	Middle	Hi Broil 22 - 27 minutes

\* The bottom broil position for the 6-inch broiler is the broiler bottom. The bottom position for the 12-inch broiler is the bottom rack position.

## Programmed Oven Operations

The Programmed Oven Operation feature can be used to turn off the oven at a specific time or delay the start and then turn off the oven.

This feature will not operate unless the clock is functioning and is set to the correct time of day.

**IMPORTANT:** Highly perishable foods such as dairy products, pork, poultry, seafood, or stuffing are not recommended for delayed cooking. If cooking more than one food, select foods that cook for the same length of time and at the same oven temperature.

### Additional Information

If you delay more than 30 seconds between touching a pad and pressing the ▲ or ▼ pad the display will either return to the previous setting or the time of day will reappear and the program will cancel.

To recall the preset stop time or cook time, just press the corresponding pad.

To reset or cancel the program, press the CANCEL pad.

### To Bake By Time (with immediate start):

1. Place the food in the oven.
2. Press the COOK TIME pad. The words "Start Cook Time" will flash in the display.
3. Enter the cooking time (how long you wish the food to cook) by pressing the ▲ or ▼ pad. The time will appear in hours and minutes. The maximum time that can be set is 11 hours and 55 minutes.
4. Press the OVEN TEMP pad. The word "Bake" and 000° will light in the display. If this is not done within 7 seconds after entering the cook time, the control will beep until another pad is pressed.
5. Enter the oven temperature with the ▲ or ▼ pad.
6. The oven will automatically turn on and the words "Timed Bake On" will light in the display. Press the COOK TIME pad to recall the remaining cooking time.
7. **At the end of the preset cooking time, oven will automatically turn off, and continuous beeps will sound.** Remove the food from the oven and press the CANCEL pad to stop the beeps. The current time of day will reappear in the display.

### Example for Immediate Start:

Food is to cook for 1-1/2 hours at 350°F.

1. Press the COOK TIME pad.
2. Press the ▲ pad until 1:30 (1 hour, 30 minutes) appears in the display.
3. Press the OVEN TEMP pad.
4. Press the ▲ pad until 350° appears in the display. The oven will turn on immediately.



## To Bake By Time (with delayed start):

1. Place the food in the oven.
2. Press the COOK TIME pad. The words "Set Cook Time" will flash in the display.
3. Enter the cooking time (how long you wish the food to cook) by pressing the ▲ or ▼ pad. The time will appear in hours and minutes. The maximum time that can be set is 11 hours and 55 minutes.
4. Press the OVEN STOP pad. The words "Set Stop Time" will flash in the display.
5. Enter the time you wish the oven to turn off by pressing the ▲ or ▼ pad. The words "Delay Stop Time" will light in the display.
6. Press the OVEN TEMP pad. The word "Bake" and 000° will light in the display.
7. Enter the oven temperature by pressing the ▲ or ▼ pad. Press the CLOCK pad and the time of day will reappear in the display. "Delay Bake" will light in the display to show that the oven has been set for a delay start cooking operation.
8. When the oven automatically turns on, "Timed Bake" will appear in the display.
9. **At the end of the preset cooking time, the oven will automatically turn off, and continuous beeps will sound.** Remove the food from the oven and press the CANCEL pad to stop the beeps. The current time of day will reappear in the display.

## Example for Delay Start:

Food is to cook for 2-1/2 hours at 350°F. You wish the food to be cooked by 6:00.

1. Press the COOK TIME pad.
2. Press the ▲ pad until 2:30 (2 hours, 30 minutes) appears in the display.
3. Press the OVEN STOP pad.
4. Press the ▲ pad until 6:00 appears in the display.
5. Press the OVEN TEMP pad.
6. Press the ▲ pad until 350° appears in the display. Press the CLOCK pad and the time of day will reappear in the display.



The oven will turn on at 3:30, cook the food for 2-1/2 hours and will automatically turn off at 6:00. Press the CANCEL pad to stop the beeps.



## MAINTENANCE

### Oven or Broiler Door

Do not place excessive weight on an open oven door or stand on an open oven door as, in some cases, it could damage the door, cause the appliance to tip over and possibly cause injury.

When opening the oven door, allow steam and hot air to escape before reaching into the oven to check, add or remove food.

**To remove:** Open the door to the “stop” position (opened about 6 inches) and grasp the door with both hands at each side. Do not use door handle to lift door. Lift up evenly until the door clears the hinge arms.

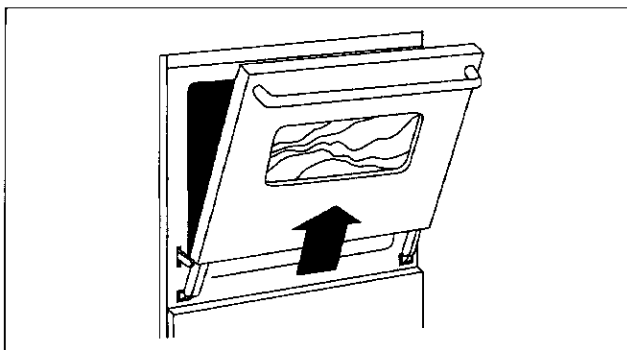

**CAUTION:** Hinge arms are spring mounted and will slam shut against the oven if accidentally hit. **Never place your hand or fingers between the hinges and the front oven frame.** You could be injured if the hinge snaps back.

**To replace:** Grasp the door at each side, align the slots in the door with the hinge arms and slide the door down onto the hinge arms until the door is completely seated on the hinges.

Do not attempt to open or close the oven door until the door is completely seated on the hinge arms. Never turn on oven unless the door is properly in place. When baking, be sure the door is completely closed. Baking results will be affected if the door is not securely closed.

### Oven Bottom

Protect the oven bottom against excessive spillovers especially acid or sugary spillover they may discolor the porcelain. Use the correct size cooking utensil to avoid boilovers. Never place cookware or aluminum foil directly on oven bottom.

**To remove:** When cool, remove the oven rack. Push the oven bottom to the rear of the oven and lift up at front until the front edge of the oven bottom clears the oven front frame. Remove oven bottom from oven.

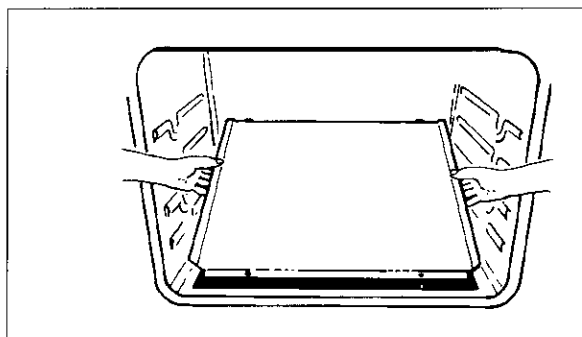

**To replace:** Fit the rear edge of oven bottom into the pin located at the center of the char on the rear oven wall. Push toward the rear of the oven and lower oven bottom into place.

### Broiler Bottom

**To remove:** When cool, remove broiler pan and oven rack. Lift up front edge of broiler bottom. Then lift rear end up and remove broiler bottom from oven.

**To replace broiler bottom for models CWG 4100 and CWG 4600:** Place two slots along rear flange over two screws in rear wall. The lower front edge into place.

**To replace broiler bottom for models CWG 3100 and CWG 3600:** Push bottom to rear and lower into place.

## Oven Light

Oven light bulb is located on the back oven wall. Before replacing light bulb, **disconnect power to oven**. Be sure bulb is cool. Do not touch a hot bulb with a damp cloth as the bulb may break. Use a dry pot holder to prevent possible harm to hands. If bulb should break, use a pot holder to protect hands and very carefully remove bulb. If bulb breaks at base, have a service technician remove bulb.

Replace with a 40 watt **appliance** bulb. Restore power to oven. Reset clock.

## Electrical Connection

Appliances which require electrical power are equipped with a three-prong grounding plug which must be plugged directly into a properly grounded three-hole 120 volt electrical outlet.

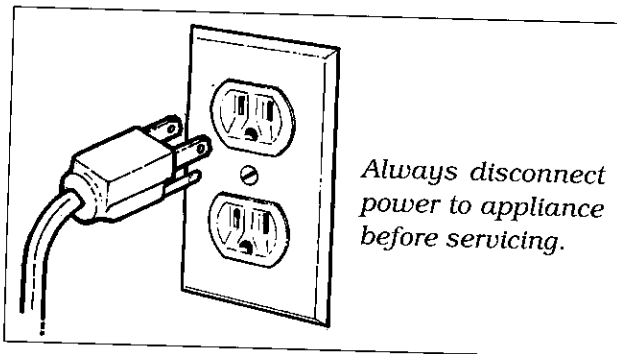

If an ungrounded, two-hole or other type electrical outlet is encountered, **it is the personal responsibility of the appliance owner to have the receptacle replaced with a properly grounded three-hole electrical outlet**. The three-prong grounding plug is provided for protection against shock hazards. **Do not cut or remove the third grounding prong from the power cord plug.**

## How To Remove Wall Oven For Servicing Or Cleaning

Follow these procedures to remove appliance for cleaning or servicing:

1. Shut-off gas supply to appliance.
2. Disconnect electrical supply to appliance.
3. Disconnect gas supply tubing to appliance.
4. Remove the screws that secure the wall oven to the cabinet. Remove oven from cabinet.
5. Reverse procedure to reinstall. If gas line has been disconnected, check for gas leaks after reconnection. See Installation Instructions for gas leak test method.

**NOTE:** A qualified servicer should disconnect and reconnect the gas supply.

**WARNING:** Possible risks may result from abnormal usage, including excessive loading of the oven door and of the risk of tip over, should the appliance not be reinstalled according to the installation instructions.

## CARE AND CLEANING

Be sure all parts of the oven are cool before cleaning. After cleaning be sure all parts are correctly.

### Cleaning Chart

Parts & Cleaning Agents	Directions
Broiler Insert and Pan <ul style="list-style-type: none"> <li>• Detergent and water.</li> <li>• Plastic scouring pad.</li> <li>• Soap-filled scouring pad.</li> <li>• Dishwasher.</li> </ul>	Remove from the appliance after use. Allow to cool, then pour off grease. Place soapy cloth over insert and soak to loosen soil. Wash in warm soapy water. Use soap-filled scouring pad to remove stubborn soil. Use dishwasher if desired.
Control Panel <ul style="list-style-type: none"> <li>• Detergent and water.</li> <li>• Mild liquid sprays.*</li> </ul>	Use a clean, soft cloth. Clean with mild liquid spray detergent and water.
Glass (Oven Door) <ul style="list-style-type: none"> <li>• Detergent and water.</li> <li>• Glass cleaner.</li> </ul>	Wash with glass cleaner or with cloth wrung out in water. Do not oversaturate cloth to avoid inside staining oven door glass. Do not use abrasive materials such as scouring pads, steel wool, or powdered cleaning agents. They will damage glass. Rinse with clear water and prevent staining of glass, never use excessive amount of water which may seep under or behind glass.
Metal Finishes (Trim Parts) <ul style="list-style-type: none"> <li>• Detergent and water.</li> </ul>	Wash with detergent and water. Do not use abrasive or caustic agents. They will damage the finish.
Oven Racks <ul style="list-style-type: none"> <li>• Detergent and water.</li> <li>• Cleansing powder and plastic pads.</li> <li>• Soap-filled scouring pads.</li> </ul>	Clean with soapy water. Remove stubborn soil with cleansing powder or soap-filled scouring pad. Rinse and dry.
Porcelain Enamel - Interior Oven and door. <ul style="list-style-type: none"> <li>• Detergent and water.</li> <li>• Cleansing powder and plastic pads.</li> <li>• Commercial oven cleaner.</li> </ul>	Clean with detergent and water when parts are cool. Acid spillovers especially acid spillovers, should be wiped immediately with a dry cloth. When surface is cool, wash with warm soapy water. Commercial oven cleaners should not be used on porcelain oven but follow manufacturer's instructions. Never wipe off a warm or hot enamel surface with a damp cloth. This may cause cracking and chipping. Never use abrasive or caustic cleaning agents on exterior finish of oven. Porcelain enamel may crack or chip with misuse.
Continuous Clean - Interior Oven (select models)	See page 19 for instructions.
Plastic Finishes (Door Handle). <ul style="list-style-type: none"> <li>• Detergent and water.</li> <li>• Mild liquid sprays.*</li> </ul>	Never use abrasive or caustic cleaning agents on plastic finishes.

\* Mild liquid sprays such as Fantastik and Formula 409.

## Continuous Cleaning Oven (select models)

**Note:** The oven door liner and oven bottom are porcelain enamel. For cleaning instructions, refer to the cleaning chart on page 18.

### What Is The Continuous Cleaning Oven?

The finish of the Continuous Cleaning Oven contains a special catalyst and is identified by its dark gray color, white stipple and rough, porous texture. The rough texture prevents grease spatters from forming beads which run down the walls leaving unsightly streaks. Rather, the rough texture absorbs spatters and allows them to spread, thus exposing a larger area to the hot oven air. The catalyst, when exposed to heat, speeds the oxidation of soil.

Cleaning action automatically begins whenever the oven is turned on for baking or roasting. The oven **MUST** be on for cleaning to take place - no cleaning will occur when the oven is off. The special catalytic finish must be exposed to hot oven air before soil will begin to gradually reduce in size.

### Factors Affecting Length Of Cleaning Time

The higher the oven temperature, the faster the cleaning action. The length of cleaning time will depend on these factors: Type of soil, amount or size of soil, oven temperature and length of time oven is in use. Time may vary from a few minutes to several hours. Soil deposited at the end of a cycle may still be visible. This will usually fade with continued oven use until the soil gradually disappears or can be wiped up manually. The oven will appear presentably clean, even though some spatters may be present.

### Manually Cleaning Heavy Spillovers

The special finish will clean most spatters during normal oven use unless there is a heavy buildup of soil. Heavy spillovers such as pie or casserole boilovers will not clean effectively without some manual help. The crusty or varnish-like stains that form from these spillovers clog the pores and prevent the special finish from being exposed to the hot oven air. This greatly reduces the cleaning effectiveness of the finish.

These crusty or varnish-like stains must either be removed or broken up before cleaning can effectively take place.

### To Manually Clean Heavy Spillovers

Brush off heavy soil with a nylon brush or plastic pad. **Do not use** paper towels, cloths or sponges for the oven walls are porous and particles of these materials will rub off on the walls. Rinse area with clear water only.

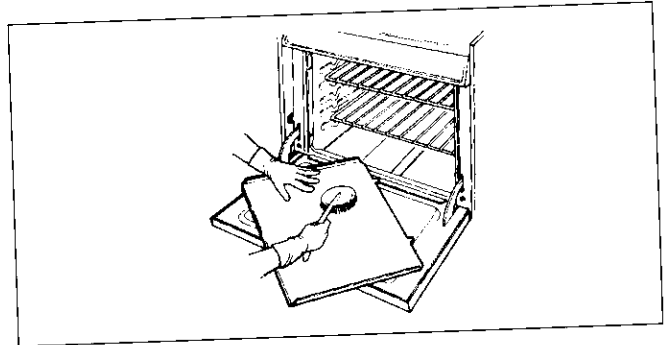

### Hints

Brittle crusts or stains can be loosened by **gently** tapping stain with a wooden or plastic utensil. Brush away any loose soil that flakes off. Varnish type stains usually need to be softened with a small amount of water or damp cloth. Remaining soil will gradually reduce with continued oven use at normal baking temperatures.

**Do not use any type of oven cleaner, powdered cleansers, soap, detergent or paste on any continuous cleaning surface. Also, do not use any abrasive materials, steel wool, sharp instruments or scrapers for they will damage the finish.**

Avoid spillovers by using utensils that are large enough to hold food. A cookie sheet or piece of aluminum foil, just a little larger than the pan, can be placed on the rack directly below the rack holding the utensil to catch spills.

Over a period of time, wear marks may appear on the embossed rack supports. This is normal and results from sliding the racks in and out of the oven. Wear marks will not affect the cleaning action of the oven.

## SERVICE INFORMATION

### Adjusting the Oven Thermostat

After using your oven the first few times, it may seem hotter or cooler than your previous oven. Oven thermostats, over a period of years, may drift from the factory setting and timing differences of 5 to 10 minutes are not unusual between an old and a new oven. You may be inclined to think that the new oven is not performing correctly; however, your new oven has been set correctly at the factory and is more likely to be accurate than the oven it replaced.

If you think the oven should be hotter or cooler, you can adjust it yourself. To decide how much to change the thermostat, set the oven temperature 25°F higher or lower than the temperature in your recipe, then bake. The results of the "test" should give you an idea of how much the thermostat should be changed.

#### To adjust the thermostat:

1. Press the OVEN TEMP pad.
2. Press the ▲ or ▼ pad and select an oven temperature between 500°F and 550°F.
3. Press and hold the OVEN TEMP pad for about four seconds. The display will change to the oven adjustment display which reads 00°.
4. The oven thermostat can be adjusted up to +35°F hotter or -35°F cooler. Use the ▲ or ▼ pad to select the desired change in the display.
5. When you have made the adjustment, press the CANCEL pad to return to the time of day display. Use your oven as you would normally.

**NOTE:** This adjustment will not affect the Broil temperature. The new temperature will be remembered if the power is interrupted.

### Fault Codes

Your oven is equipped with an electronic control featuring built-in, self-diagnostic software. This software continuously monitors the control to ensure safe and proper operation. If the software should detect a questionable situation, a FAULT CODE (a number) will appear in the display and continuous beeps will sound.

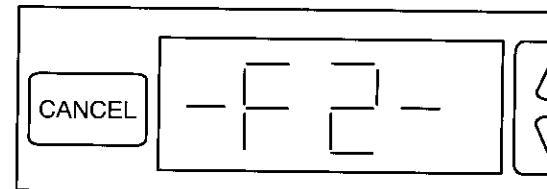

A fault code indicates that there may be a functional error. As a safety precaution, the control will automatically cancel the program. Follow the procedures described below to check the wall oven.

#### During Normal Oven Cooking:

If a fault code appears in the display, press the CANCEL pad and reprogram the cooking operation. If the fault code reappears, call a qualified service technician. Do not use the oven until the appliance has been serviced.

## Before You Call For Service

Check these points if . . .

### Part or all of your wall oven does not operate

- Is the wall oven plug loose or disconnected from the electrical outlet (if not wired direct to the electrical supply)?
- Are any house fuses blown or circuit breakers tripped?
- Has the power or gas supply to the home been interrupted?
- Are the oven controls properly set?
- Is the oven set for programmed cooking?

### Food not baking correctly

- Are the oven racks properly placed for baking?
- Have you used aluminum foil correctly?
- Was the oven preheated as recommended?
- Are the controls for bake operations properly set?
- Is there 1 to 2 inches of space between pans and the oven walls? Are the wall oven and oven racks level?
- Was good cookware/bakeware of the proper size used?
- Are you using a tested recipe from a reliable source? The oven thermostat on your new wall oven may be more accurate than the one on your old wall oven.
- Was the oven vent covered or blocked on the wall oven surface?
- Is your oven level?

### Food does not broil properly

- Are the controls for broiling set properly? (See Broiling section, page 13.)
- Was the proper rack position used? (See Broiling section, page 13.)
- Was the broiler pan received with the wall oven used?
- Was aluminum foil used on the broiler pan insert, blocking the slits for fat drainage?

### Oven light does not operate

- Is the bulb loose or burned out?
- Is the light switch in the On position? (Select models.)

### "F" plus a number appears in the display

- These are fault codes. If a fault code appears in the display and a continuous beep sounds, press the CANCEL pad and reset the cooking operation. If the fault code reappears, disconnect power to the wall oven and call a qualified service technician.

**NOTE: For further assistance contact your Maytag Dealer or call Maytag Customer Service.**

**US ..... 1-800-688-9900**  
**Canada ..... 1-800-688-2002**

# WALL OVEN WARRANTY

## Full One Year Warranty

For **one (1) year** from date of original retail purchase, any part which fails in normal home use will be repaired or replaced free of charge when the appliance is located in the United States or Canada.

## Limited Parts Warranty

**All Wall Ovens:** After the first year from the date of original retail purchase, through the second year, parts which fail in normal home use will be repaired or replaced free of charge for the part itself, with the owner paying all other costs, including labor, when the appliance is located in the United States or Canada.

**All Heating Elements:** After the second year from the date of original retail purchase through the fifth year, the oven bake element and oven broil element in electric wall ovens which fail in normal home use will be repaired or replaced free of charge for the part itself, with the owner paying all other costs, including labor, when the appliance is located in the United States or Canada.

## Limited Parts Warranty Outside The United States Or Canada

For two (2) years from the date of original retail purchase, any part which fails in normal home use will be repaired or replaced free of charge for the part itself, with the owner paying all other costs, including labor, when the appliance is located outside the United States or Canada.

This Warranty gives you specific legal rights, and you may also have other rights which vary from state to state.

## To Receive Warranty Service

To locate an authorized service company in your area contact the Maytag dealer from whom your appliance was purchased; or call Maytag Customer Service. Should you not receive satisfactory warranty service, call or write:

Maytag Customer Assistance  
c/o Maytag Customer Service  
P.O. Box 2370  
Cleveland, TN 37320-2370  
**US 1-800-688-9900**  
**CANADA 1-800-688-2002**

When contacting Maytag Customer Service be sure to provide the model and serial number of your appliance and the name and address of the dealer from whom you purchased the appliance and the date of purchase.

**Should you still have a problem,** write to: Major Appliance Consumer Action Program, 20 North Wacker Drive, Chicago, Illinois 60606. MACAP is an industry sponsored but independent group of consumer experts who receive and act on complaints from appliance owners.

- NOTE:** When writing about an unsolved service problem, please include the following information:
- Your name, address and telephone number;
  - Model number and serial number (found on the data plate located on the left or lower right side of oven trim on a single oven and on the lower right side of oven trim on a double oven) of your appliance;
  - Name and address of your dealer and date the appliance was bought;
  - A clear description of the problem you are having.